

CAD FLIE:

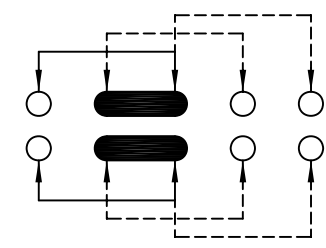

SCHEMATIC (SHORTING)

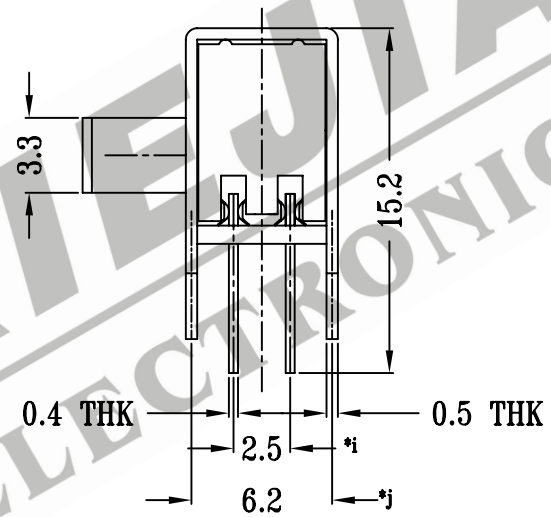
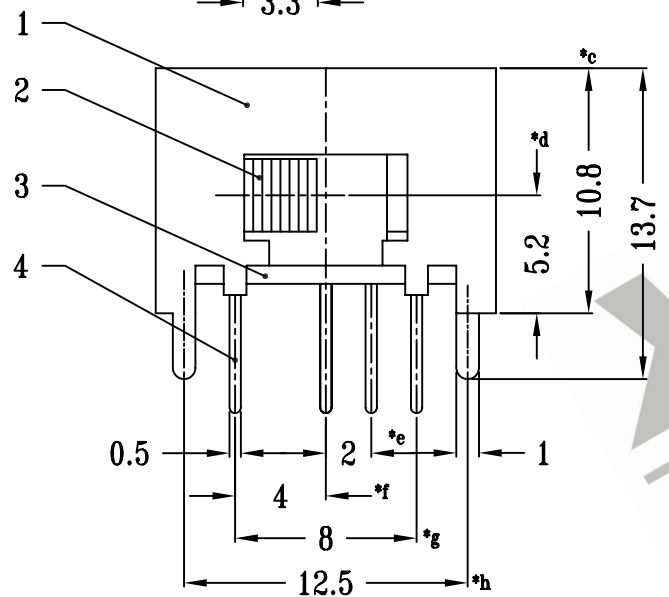
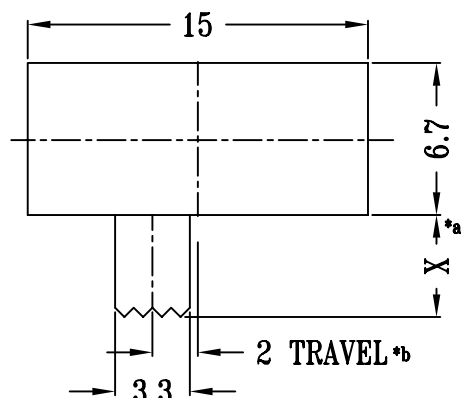
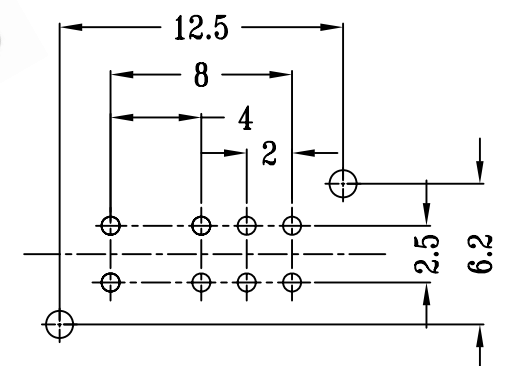

P.C.B LAYOUT

注:带"\*"表示关键尺寸(7个)

					TOLERANCE UNLESS SPECIFIED		SHENZHEN XIEJIA ELECTRONICS CO.,LTD.			
7	3/32" STEEL BALL	STEEL	1	NATURAL	WITHIN: 1.5±0.1mm		ISSUE		DATE	
6	32# SPRING	STEEL WIRE	1	TEMPER	OVER: 1.5±0.2mm		DESCRIPTIONS		APPD.	
5	43 CONTACT (CLIP)	PBS STRIP	2	Ag PLATED	TITLE : HORIZONTAL SLIDE SWITCH		UNIT : MM		DRWG NO.:XJ-DR-SK23D03-00	
4	TERMINAL	TERMINAL	8	Ag PLATED OVER Ni PLATED			SCALE: 3:1		DWN.	ZHOUYU
3	TERMINAL BASE	PHENOLIC RESIN	1	NATURAL	MODEL: SK23D03		CHK'D		FANGYING	2001-9-5
2	KNOB	POM	1	BLACK			APPD.		KANGXINAN	2001-9-5
1	FRAME	STEEL STRIP	1	Ni PLATED	ALL MATERIALS MUST BE COMPLIANT TO ROHS					
NO.	PART NAME	MATERIAL	Q'TY	FINISHING						